



PRE-ADMISSION TESTING SAMPLE QUESTIONS - COMPREHENSIVE TECHNICAL MATH

Testing Information:

- Multiple choice style, computer based test, timed at 2 hours
- Topics include: fractions, decimals, percents, order of operations, laws of signs, basic algebra, equations, exponents, radicals, algebraic fractions, mensuration, trigonometry & geometry, linear equations and logarithms (approx. 70 questions)
- Calculators are not permitted, scrap paper and pencils can be used for rough calculations
- Please note, the sample questions were designed to show the types of questions and topics that will be covered. Applicants may use a calculator for the sample questions although, the calculations will not be as complex on the test. The test is also multiple choice and calculators will not be permitted although scrap paper will be supplied.

For information regarding minimum score requirements for eligibility into your program, please contact Admissions.

Testing Policies:

- Pre-Admission math tests are valid for three (3) Mohawk College intake terms. Intake terms include Fall, Winter and Summer.
- It replaces a Math from your transcript for eligibility into a program at Mohawk College only.
- The grades are not transferrable to other colleges
- **Photo I.D** is required for check-in. You will not be permitted to test without valid photo I.D.

If you require testing accommodations due to a disability, please call the Testing Centre at 905-575-2448.

Pre-Admission Testing Centre
905-575-2448
preadmissiontesting@mohawkcollege.ca

PRE-ADMISSION TESTING SAMPLE QUESTIONS -
COMPREHENSIVE TECHNICAL MATH

Topic 1: Fractions

- 1) Reduce $\frac{9}{36}$
- 2) Convert this fraction into a mixed number in lowest terms $\frac{60}{25}$
- 3) Find the Least Common Denominator of $\frac{1}{3}, \frac{1}{15}, \frac{1}{9}$
- 4) Two pins measure $\frac{3}{6}$ and $\frac{4}{9}$
 - a) What is the length of the larger pin?
 - b) What is the length difference between the two pins?
- 5) Add the fractions and bring your answer to lowest terms $\frac{1}{5} + \frac{1}{10} + \frac{1}{6}$
- 6) Add $2\frac{1}{2} + \frac{1}{4} + \frac{1}{5}$
- 7) Add $4\frac{1}{3} - 1\frac{1}{7}$
- 8) Multiply $4\frac{2}{9} \times 1\frac{1}{6}$
- 9) Divide $3\frac{1}{2} \div 1\frac{2}{3}$
- 10) Simplify $9\frac{3}{4} + \frac{1}{5}$
 $\frac{5}{8}$
- 11) Find the value of x given $\frac{x}{23} = \frac{15}{3}$

Topic 2: Decimals

- 1) Divide 1.3289 by 0.431 and round to three decimal places
- 2) Convert $158\frac{3}{5}$ to a decimal. Round to one decimal place.
- 3) Convert 11.78 to a mixed fraction
- 4) Evaluate $2,300 + 3.13 + 1.09$. Round to one decimal place.
- 5) Evaluate $1.35 - 26.491 + 11.7$. Round to three decimal places.
- 6) Evaluate $0.6 \times 12.34 \times 1.4$. Round to two decimal places.
- 7) Divide 1.113 by 0.56. Round to three decimal places
- 8) Determine the volume of an aquarium with these definitions:
Length = 78 cm; Width = 6 cm; Height = 43 cm
- 9) Bob makes \$888.87 per week before deductions. The following deductions are made from his paycheque: Income Tax \$124.00; Company Pension \$42.86; C.P.P. \$38.97; and Dental Plan = \$31.97.
What are his total Deductions? What is his take-home pay?
- 10) Determine how much change you would get from \$100 if you purchased 31.9 litres of gas at a cost of 96.7 cents per litre.

Topic 3: Percents

- 1) Express the following as percents:

Decimal	Percent
a) 0.62	
b) 3.312	
c) 13	

- 2) Express the following percents as decimals:

Percent	Decimal
a) 79 %	
b) 317.2 %	
c) $14\frac{1}{3}$ %	

- 3) Express the following fractions as percents:

Fraction	Percent
a) $\frac{887}{962}$	
b) $\frac{14}{100}$	
c) $7\frac{7}{14}$	

- 4) Express the following percents in fractional form in lowest terms:

Percent %	Fraction Form
a) 86 %	
b) 52 %	
c) $7\frac{1}{2}$ %	

- 5) Determine $89\frac{1}{2}$ % of \$ 3,633 rounded to the nearest cent.

- 6) 316 kg is 15% of what measurement?

- 7) Helmer Co. Produces 1,090 DVD's per year. If 1.4% of these are defective, how many defective DVD's are produced per year? Round your answer to the nearest whole number.

- 8) Mohawk Digital Centre sells webcams for \$120 each. In an attempt to increase profit they increased the price by \$5.81. Express this increase as a percent of the original price.

- 9) Mohawk Digital Centre sells digital cameras for \$390.45 each. In an attempt to increase sales they reduced the price by 2%. What is the new price after the reduction?

Topic 4: Order of Operations

- 1) Evaluate the expression to two decimal places:

$$5 + 5 - 8 + 4 \div 6$$

- 2) Evaluate the expression to two decimal places:

$$(2 \div 6 \times 5)^2 \div 5 - 6$$

- 3) Evaluate the expression to two decimal places:

$$6 - \lceil 8 - (2 + 9 \times 3) \rceil \rceil$$

- 4) Evaluate the expression to two decimal places:

$$4^2 - \{9^3 + \lceil \lceil 1^3 - (4 + 3) \rceil \rceil \}$$

- 5) The formula to obtain the area of a certain shape is:

$$Area = \frac{L}{2} (w + d - t)$$

Determine the area when:

$$L = 18 \text{ m}; t = 2.3 \text{ m}; w = 4.6 \text{ m}; d = 10.1 \text{ m}$$

- 6) Calculate the future value of S of an annuity using the following formula:

$$S = R \left[\frac{\lceil (1 + i)^n - 1 \rceil}{i} \right]$$

$$\text{Given: } R = \$250; i = 0.01; n = 13$$

- 7) Calculate the Book Value B using the following formula:

$$B = P - \left[\frac{\lceil 5m(2n - 0.75m) \rceil}{n^3 - 2} \right] (P - S)$$

$$\text{Given: } P = \$151,788; m = 9; n = 11; S = \$35,000$$

Topic 5: Laws of Signs

1) Simplify: $-[\lceil + (-19) \rceil]$

2) Simplify: $-[-(-234)]$

3) True or False? $|-88| = |88|$

4) True or False? $-96 > -105$

5) Evaluate: $7 + \frac{1}{-3} + 4\frac{1}{6}$

6) Evaluate:

$$\left(\begin{array}{c} 7 \\ 3 \end{array} \right) \left(\begin{array}{c} 3 \\ -4 \end{array} \right) \div (-2)$$

7) A person leaves the bus terminal and goes 15 blocks WEST for coffee. Next, he goes 2 blocks EAST to mail a letter and then 5 blocks WEST to visit a friend. Upon leaving his friend's house he is struck by a car and an ambulance takes him 9 blocks EAST to the hospital. Determine the direction and number of blocks he must travel from the hospital to make it back to the bus terminal.

Topic 6: Exponents

Enter your answer in fraction form:

1) Evaluate: $\left(\frac{2}{8}\right)^2$

2) Evaluate: $(5^2)^2$

3) Evaluate: $(4x)^{-3}$; $4x^{-3}$; $4(x)^{-3}$

4) Evaluate:

$$-4A^2(3AB^3 + 4A^4B + 6A^{-5}B^4)$$

5) Simplify:

$$\left(\frac{2}{3}x^2\right)(15x^2 - 9)$$

6) Simplify: $\frac{17x^7y^9}{30x^1y}$

7) Simplify: $(2x^7y^4)^3$

8) Simplify: $\frac{3y(3x + y^2)^{19}}{10x(3x + y^2)^3}$

9) Simplify and eliminate all negative exponents: $\frac{6x^{-2}y^4}{12x^4y^{-4}}$

10) Simplify and eliminate all negative exponents: $4(x^{-7}y^2)^{-3}$

Topic 7: Basic Algebra

1) Perform the indicated operations and simplify:

$$3a - 3b - 27a + 9b$$

2) Simplify. Round the coefficient part of your answer to four decimal places:

$$\frac{3x}{2} + 4x - x$$

3) Perform the indicated operations and simplify:

$$5x - 3[(11x - 5) - (x - 2)]$$

4) Perform the indicated operations and simplify:

$$13x - (x - 3y) - [2x - (x - y)]$$

5) Perform the indicated operations and simplify:

$$(x^2 - xy - 5y^2) - (19x^2 - 7xy - y^2)$$

6) Expand and Simplify:

$$(3a - 5b)^2$$

7) Perform the indicated operation(s) and simplify:

$$18xy(3x^2)$$

8) Perform the indicated operations and simplify:

$$(x - 24)(3x^2 - 3x - 4)$$

9) Perform the indicated operations and simplify:

$$23(x + y)(4y)(y^4)$$

10) Perform the indicated operations and simplify:

$$\frac{240a^2b - 60ab + 105ab^2}{30ab}$$

Topic 8: Equations

1) Solve for B in fraction form: $4B + 15 = 100$

2) Solve for x: $ad = 12ax + 25$

3) Solve for x in fraction form: $\frac{2}{3}x + 16 = 19$

4) Solve for E in fraction form: $7E + 3(8 - 4E) = -20$

5) Solve for y: $V = \frac{t}{7}(x + y)$

6) Solve for x: $\frac{3x - 1}{2} = \frac{1}{2} + \frac{2x - 1}{2} + 1$

7) Solve for R: $D = \sqrt{\frac{R - r}{R + r}}$

8) A formula used for gear calculation is:

$$S = T - \frac{1.299}{N}$$

a. Solve for N

b. Calculate the value of N when S = 49 and T = 60

9) A formula used in pipe calculation is: $A = \frac{M}{P}(P + t)$

a. On a piece of paper, re-write this formula and solve for t, the pipe thickness.

b. Determine the value of t when A = 48.31, M = 16.12 and P = 3.55

Topic 9: Radicals

1) Write the expression in exponential form:

a. \sqrt{x}

b. $\sqrt[3]{x^2}$

c. $\sqrt[4]{ab}$

d. $\sqrt{a^3b^5}$

2) Evaluate:

a. $\sqrt{9}$

b. $\sqrt[3]{27}$

c. $\sqrt[4]{256}$

d. $\sqrt[3]{-125}$

3) Simplify each of the following:

Assume that x, y and z are positive real numbers.

a. $\sqrt{4x^2y^4}$

b. $\sqrt{25x^6y^2z^8}$

c. $\sqrt[3]{x^3y^6}$

d. $\sqrt[3]{27x^6y^9z^4}$

Topic 10: Algebraic Fractions

1) Perform the given operation and simplify the following algebraic fractions:

a. $\frac{x}{2} - \frac{y}{4}$

b. $\frac{3x}{y} + \frac{4}{3y}$

2) Multiply and simplify the following algebraic fractions:

a. $\frac{b}{2a} \cdot \frac{3ab}{a-b}$

b. $\frac{x}{3y} \cdot \frac{6y}{x-y}$

c. $\left(1 + \frac{a}{b}\right) \cdot \frac{a}{a+b}$

d. $\left(1 + \frac{b}{a}\right) \cdot \frac{2a}{a+b}$

3) Divide and simplify the following algebraic fractions:

a. $\frac{ab}{c} \div \frac{ab}{d}$

b. $\frac{ab}{2c} \div \frac{ab}{6d}$

c. $\left(1 - \frac{a}{b}\right) \div \left(1 + \frac{a}{b}\right)$

d. $\left(1 - \frac{2m}{n}\right) \div \left(1 + \frac{2m}{n}\right)$

Topic 11: Mensuration

1) Determine the area of the following figure.

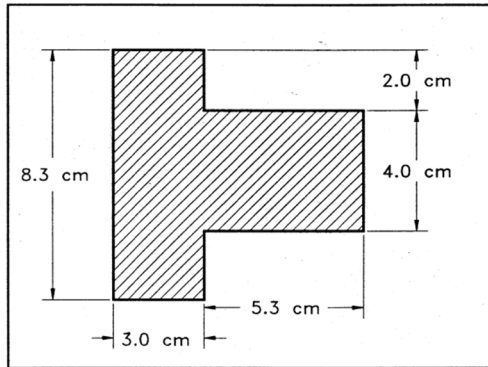

2) Determine the area of the following figure.

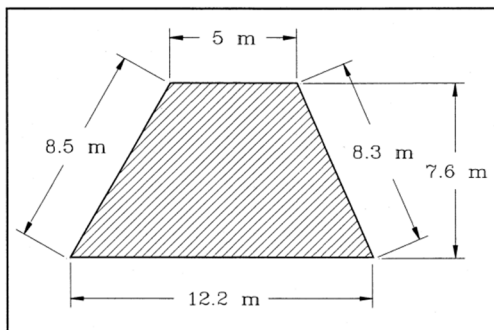

3) Determine the perimeter and area of the following figure.

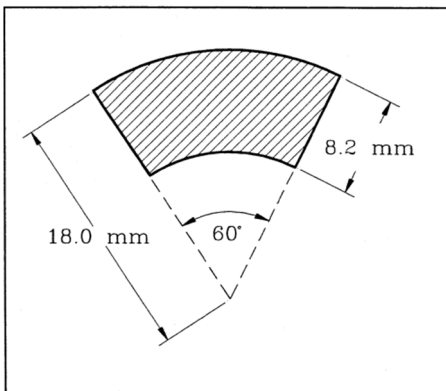

4) Determine the shaded area:

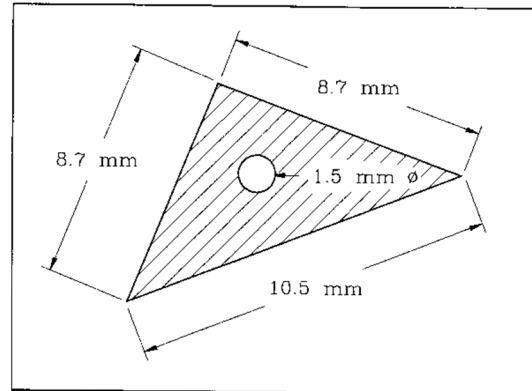

5) Determine the shaded area:

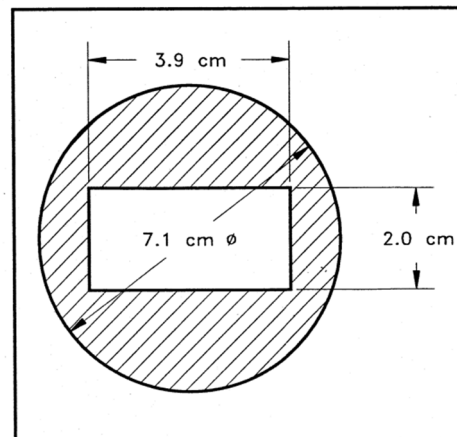

6) Determine the volume and total surface area of the right triangular prism shown.

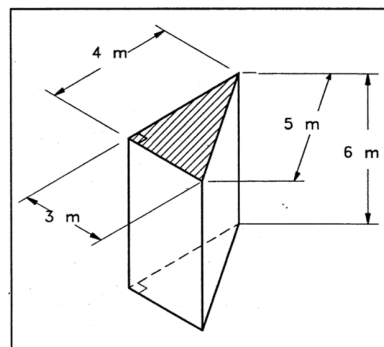

- 7) Determine the volume and surface area of the spherical tank with a diameter of 12.8 metres.

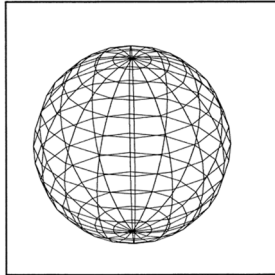

- 8) Determine the volume and total surface area of the illustrated covered conical container.

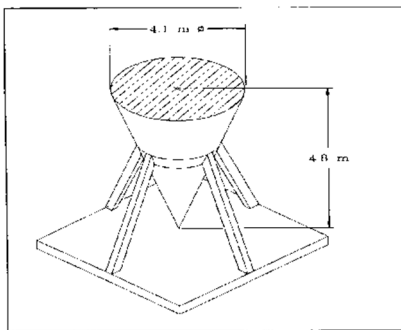

- 9) Determine the total volume of the tank shown. The top is spherical in shape.

- 10) Determine the mass of the part shown if it is constructed from material that has a density of 0.0008 kg/cm^3 . Density is mass per unit volume ($D = \frac{M}{V}$)

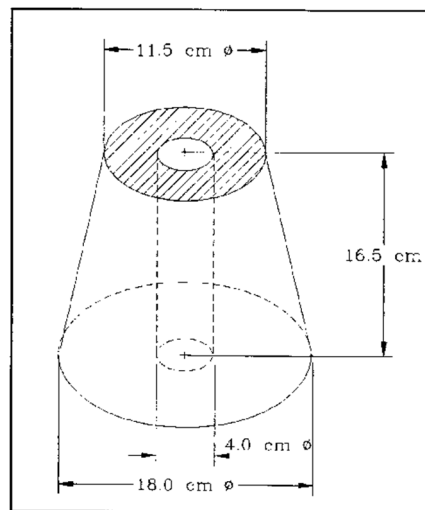

- 11) Determine the total volume of the figure shown.

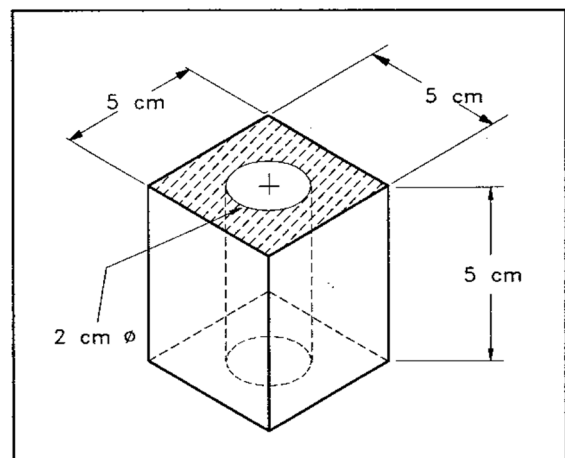
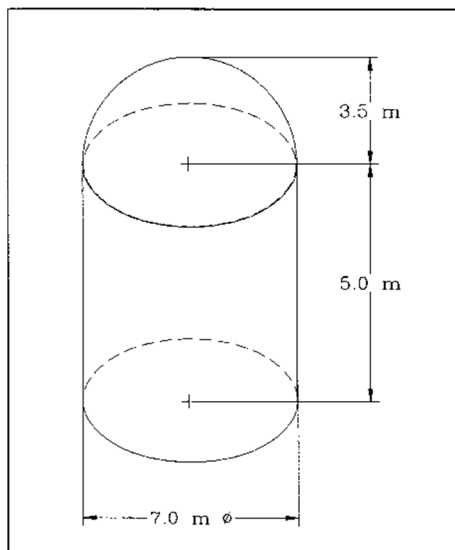

Topic 12: Trigonometry & Geometry

- 1) Determine the length of the unknown side (x) for the following triangle:

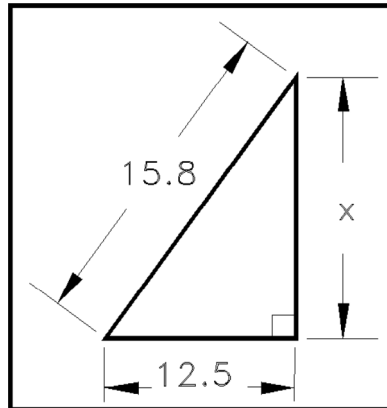

- 3) Determine the value b in the given figure.

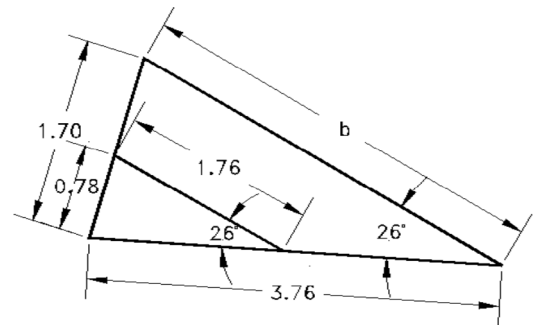

- 2) Determine the value e in the given figure.

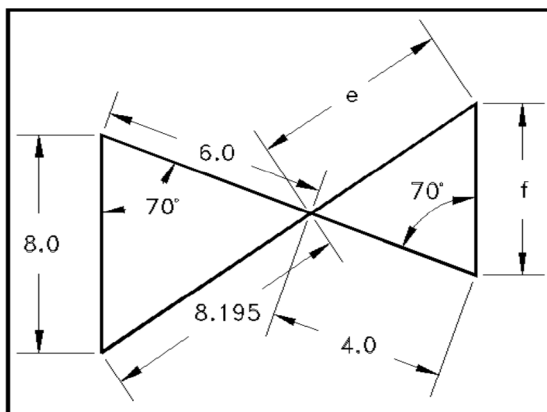

- 4) Determine the radius (r) of the circle shown.

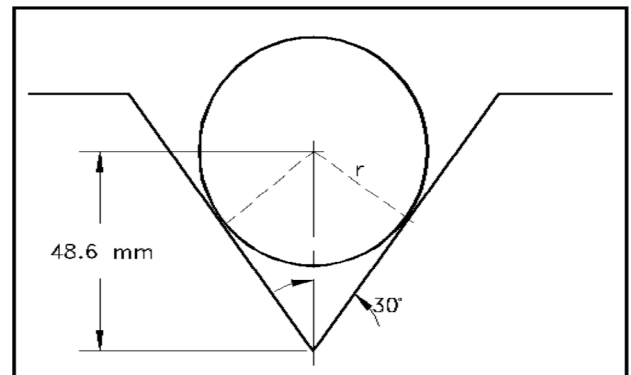

- 5) Determine the width (x) across the top of the dovetail.

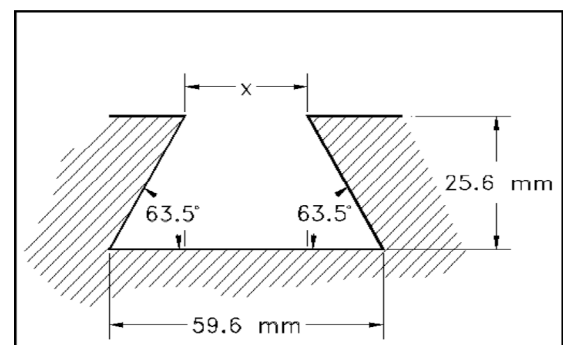

- 6)
- Convert $8^{\circ}4'57''$ to decimal degrees (6 decimal places).
 - Convert $29^{\circ}32'14''$ to decimal degrees (6 decimal places).
 - Convert 43.620514° to degrees, minutes and seconds.
 - Convert 80.012564° to degrees, minutes and seconds.

- 7) Evaluate the following to 6 decimal places.
- $\sin(-83.45^{\circ})$
 - $\csc(25.3^{\circ})$
 - $\tan(10^{\circ}25'18'')$
 - $\sec 21.88^{\circ}$

- 8) Determine angle **A** indicated for the given shaft.

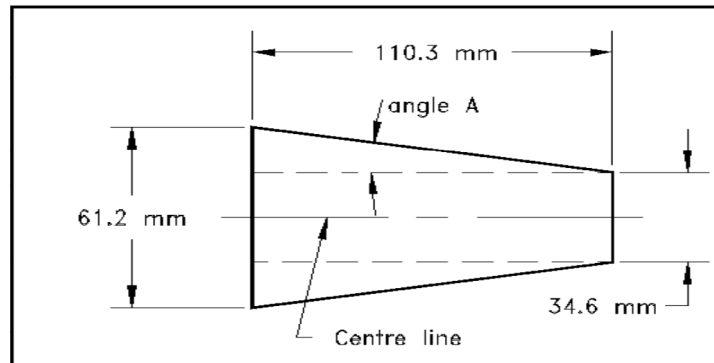

- 9) Determine the angle (**A**) indicated.

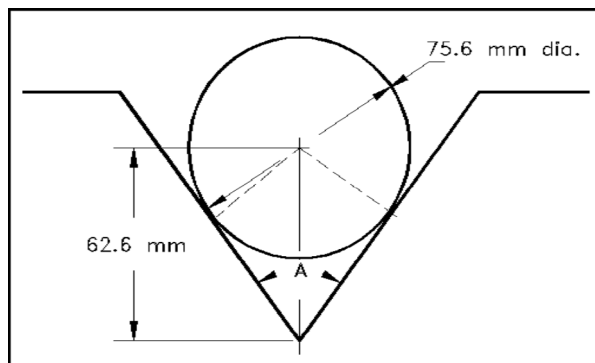

- 10) Determine the missing dimension, (**H**).

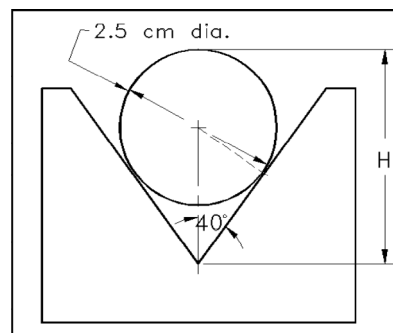

Topic 13: Linear Equations

- 1) Plot the data and draw a line through the data points.
Proper graphing procedure required.

x	7	7.6	9.1	9.8	10.7	8.3
y	410	360	250	190	110	310

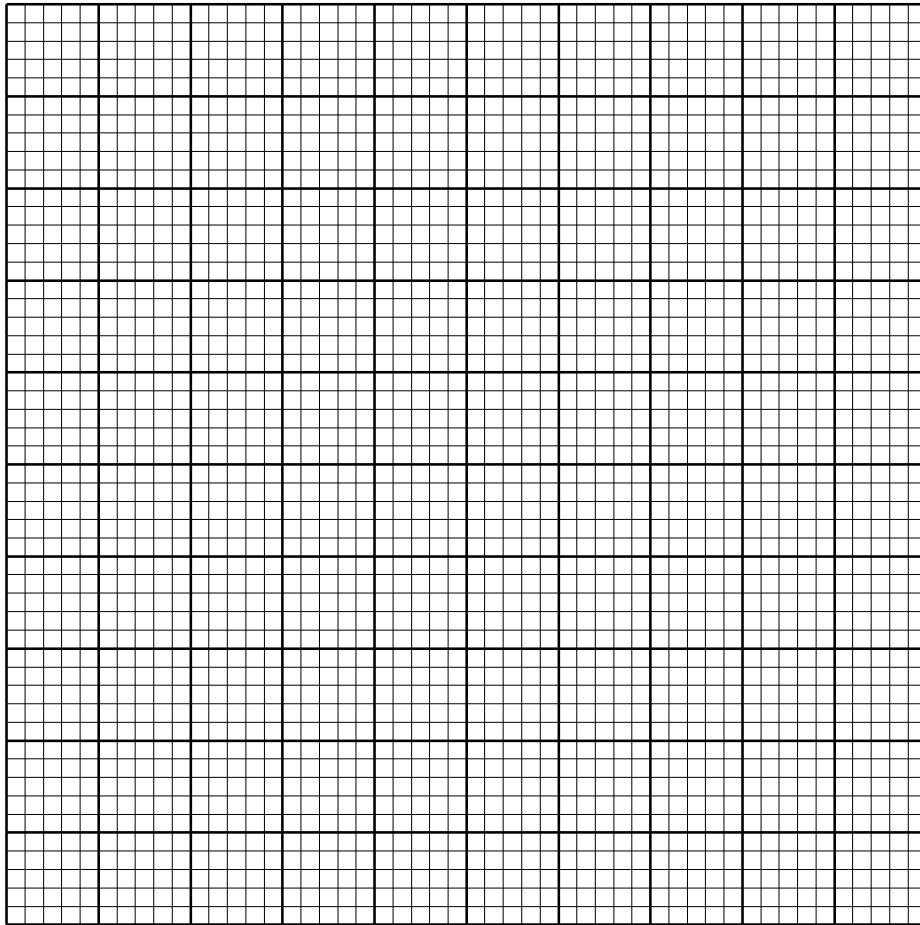

- 2) Solve algebraically using the addition method.

$$5m + 3n = 17$$

$$4m + 2n = 8$$

3) Solve algebraically using the method of substitution.

$$8x + 5y = -8$$

$$2x - y = 7$$

4) Solve the following system of equations graphically.

$$-3x = 4y - 9$$

x	
y	

$$8x - 9y = 36$$

x	
y	

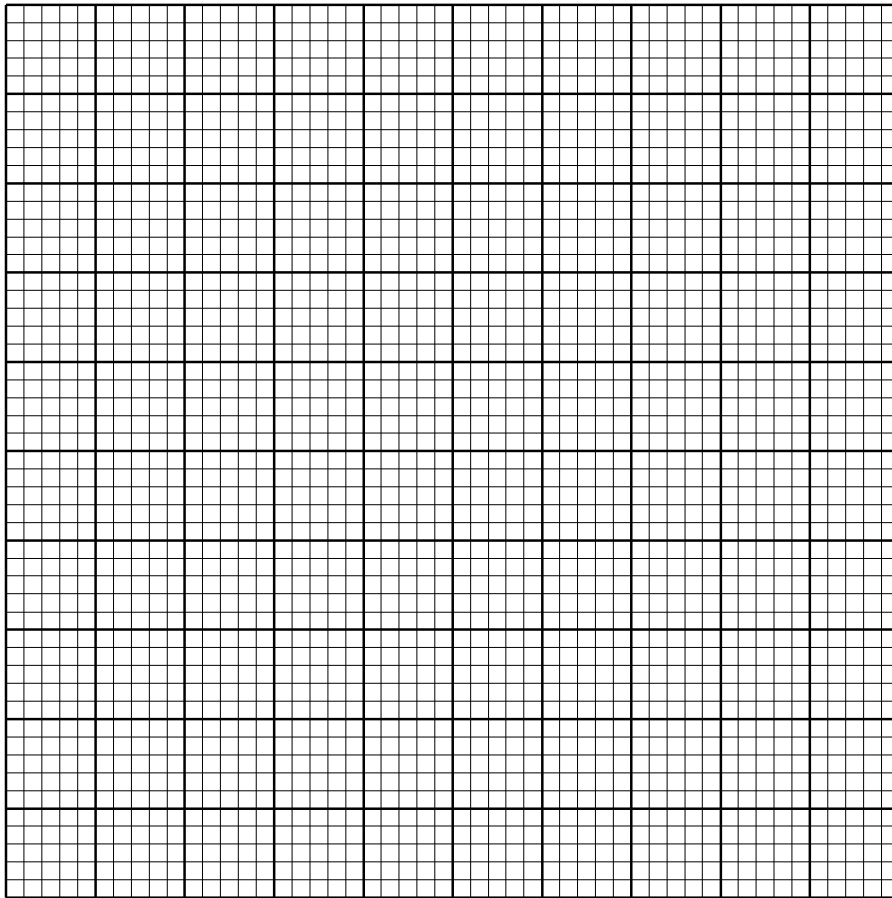

5) A line drawn to join two points $(-6, 3)$, $(7, -2)$ Calculate the following:

- a. The distance between the two points
- b. The slope of the line.

- 6) Draw a line through the point $(0, 2)$ with a slope of $-\frac{2}{5}$. Also determine:
- The equation of the Line
 - The x and y intercepts of the line

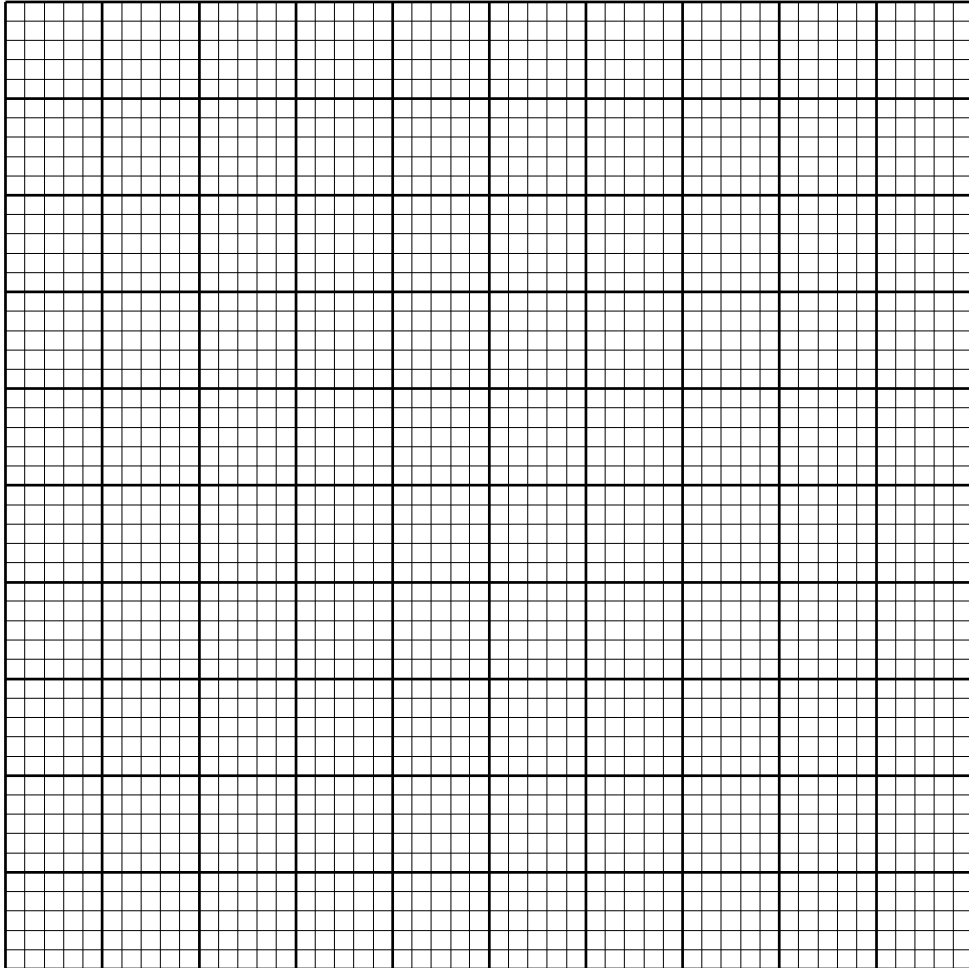

- 7) Determine the equation of the line perpendicular to the line $y = 3x$, and passing through $(6, -2)$.
- 8) Determine the equation of the line passing through $(-1, 5)$ and $(8, 20)$
- 9) Convert $2(x - 4) - 2(y + 5) = 7$ to the slope – intercept form.

Topic 14: Logarithms

- 1) Convert each given exponential equation to its equivalent logarithmic form, and convert each given logarithmic equation to its equivalent exponential form.

EXPONENTIAL FORM	LOGARITHMIC FORM
$X^3 = 346$	
$N^{3.7} = R$	
	$\log_2 94 = P$
	$\log_{10}(3R) = 2.43$
$e^{1.5t} = 10.3$	
$e^{2x} = 5$	
	$\log_x (1200) = R$
	$\log_x (0.7) = -2.43$

$4^2 = 16$	
------------	--

- 2) Convert to exponential form and solve for the unknown.

LOG FORM	EXPONENTIAL FORM	ANSWER
$\log_3 81 = X$		$X =$
$\log_x 6 = \frac{1}{2}$		$X =$
$\log_2 X = 4$		$X =$
$\log_{10} 0.001 = X$		$X =$
$3 = \log_R 1000$		$R =$

- 3) Using the PROPERTIES OF LOGS expand the given log terms and combine the given log expressions:

COMBINED FORM	EXPANDED FORM
$\log_{10} \left[\frac{\pi R^2}{T} \right]$	
$\log_{10} \left[\frac{x-R}{j} \right]$	
$\log_{10} \left[\frac{4}{x+y} \right]^{1/2}$	
	$3.2 [\log_{10} 2 + \log_{10} P]$
	$\frac{1}{2} \log_{10} (7.6) + \log_{10} J + \log_{10} K$
	$2 [\log_{10} N + \log_{10} 5.73 - \log_{10} R]$

Answer Sheet – Comprehensive Technical Math

Topic 1: Fractions

- 1) $\frac{1}{4}$
- 2) $2\frac{2}{5}$
- 3) 45
- 4) $\frac{1}{2}, \frac{1}{18}$
- 5) $\frac{7}{15}$
- 6) $2\frac{19}{20}$
- 7) $3\frac{4}{21}$
- 8) $4\frac{25}{27}$
- 9) $2\frac{1}{10}$
- 10) $15\frac{23}{25}$
- 11) 115

Topic 2: Decimals

- 1) 3.083
- 2) 158.6
- 3) $11\frac{39}{50}$
- 4) 2,304.2
- 5) 13.441
- 6) 10.37
- 7) 1.988
- 8) 20,124 cm^3
- 9) \$237.80; \$651.07
- 10) \$69.15

Topic 3: Percents

- 1)
 - a. 62 %
 - b. 331.2 %
 - c. 1 300 %

- 2)
 - a. 0.79
 - b. 3.172
 - c. 0.143

- 3)
 - a. 92.2 %
 - b. 14 %
 - c. 750 %

- 4)
 - a. $\frac{43}{50}$
 - b. $\frac{13}{25}$
 - c. $\frac{3}{40}$

- 5) \$3251.54

- 6) 2 106.67 kg

- 7) 15

- 8) 4.84%

- 9) \$382.64

Topic 4: Order of Operations

- 1) 2.67
- 2) -5.44
- 3) 27
- 4) -707
- 5) $111.6 m^2$
- 6) \$3452.33
- 7) \$91482.68

Topic 5: Laws of Signs

- 1) 19
- 2) -234
- 3) True
- 4) True
- 5) $10\frac{5}{6}$
- 6) $2\frac{3}{4}$
- 7) Nine blocks in the East Direction

Topic 6: Exponents

- 1) $\frac{1}{16}$
- 2) 625
- 3) $\frac{1}{64x^3}$; $\frac{4}{x^3}$; $\frac{4}{x^3}$
- 4) $-12A^3B^3 - 16A^6B - 24A^{-3}B^4$
- 5) $10x^4 - 6x^2$
- 6) $\frac{17x^6y^8}{30}$
- 7) $8x^{21}y^{12}$
- 8) $\frac{3y(3x+y^2)^{16}}{10x}$
- 9) $\frac{y^8}{2x^6}$
- 10) $\frac{4x^{21}}{y^6}$

Topic 7: Basic Algebra

- 1) $-24a + 6b$

- 2) $4.5x$
- 3) $-25x + 9$
- 4) $11x + 2y$
- 5) $-18x^2 + 6xy - 4y^2$
- 6) $9a^2 - 30ab + 25b^2$
- 7) $54x^3y$
- 8) $3x^3 - 75x^2 + 68x + 96$
- 9) $92xy^5 + 92y^6$
- 10) $\frac{16a-4+7b}{2}$

Topic 8: Equations

- 1) $B = \frac{85}{4}$
- 2) $x = \frac{ad-25}{12a}$ or $x = \frac{d}{12} - \frac{25}{12a}$
- 3) $x = 9/2$
- 4) $E = \frac{44}{5}$
- 5) $y = \frac{7V}{t} - x$ or $y = \frac{7V-tx}{t}$
- 6) $x = \frac{1.5}{0.5} = 3$
- 7) $\frac{-r(1+D^2)}{(D^2-1)}$ or $\frac{-r-D^2r}{(D^2-1)}$
- 8) a. $N = -\frac{1.299}{(S-T)}$ b. 0.118
- 9) a. $t = \frac{AP}{M} - P$ b. $t = 7.09$

Topic 9: Radicals

- 1)
 - a. $x^{\frac{1}{2}}$
 - b. $x^{\frac{2}{3}}$

c. $(ab)^{\frac{1}{4}}$ or $a^{\frac{1}{4}}b^{\frac{1}{4}}$

d. $(a^3b^5)^{\frac{1}{2}}$ or $a^{3/2}b^{5/2}$

2)

a. 3 b. 3

c. 4 d. -5

3)

a. $2xy^2$

b. $5x^3yz^4$

c. xy^2

d. $3x^2y^3z^{\frac{4}{3}}$

Topic 10: Algebraic Fractions

1)

a. $\frac{2x-y}{4}$

b. $\frac{9x+4}{3y}$

2)

a. $\frac{3b^2}{2a-2b}$

b. $\frac{2x}{x-y}$

c. $\frac{a}{b}$

d. 2

3)

a. $\frac{d}{c}$

b. $\frac{3d}{c}$

c. $\frac{b-a}{b+a}$

d. $\frac{n-2m}{n+2m}$

Topic 11: Mensuration

- 1) $P = 33.2 \text{ cm}$ $A = 46.2 \text{ cm}^2$
- 2) $P = 34 \text{ m}$ $A = 65.36 \text{ m}^2$
- 3) $P = 45.5 \text{ mm}$ $A = 119.3 \text{ mm}^2$
- 4) $A = 34.653 \text{ mm}^2$
- 5) $A = 31.79 \text{ cm}^2$
- 6) $V = 36 \text{ m}^3$ $\text{TSA} = 84 \text{ m}^2$
- 7) $V = 1098.07 \text{ m}^3$ $\text{SA} = 514.719 \text{ m}^2$
- 8) $V = 21.124 \text{ m}^3$ $\text{TSA} = 46.816 \text{ m}^2$
- 9) $V = 282.2 \text{ m}^3$
- 10) $V = 2657.5 \text{ cm}^3$ $\text{Mass} = 2.126 \text{ kg}$
- 11) $V = 109.29 \text{ cm}^3$

Topic 12: Trigonometry & Geometry

- 1) $x = 9.66$
- 2) $e = 5.46$
- 3) $b = 3.84$
- 4) $r = 24.3 \text{ mm}$
- 5) $x = 34.04$
- 6)
 - a. $8.082 \ 500^\circ$
 - b. $29.537 \ 222^\circ$
 - c. $43^\circ \ 37' \ 13.85''$
 - d. $80^\circ \ 0' \ 45.23''$
- 7)
 - a. $-0.993 \ 473$
 - b. $2.339 \ 959$
 - c. $0.183 \ 925$
 - d. $1.077 \ 625$
- 8) Angle $A = 6.88^\circ$
- 9) Angle $A = 74.29^\circ$
- 10) $H = 3.20 \text{ cm}$

Topic 13: Linear Equations

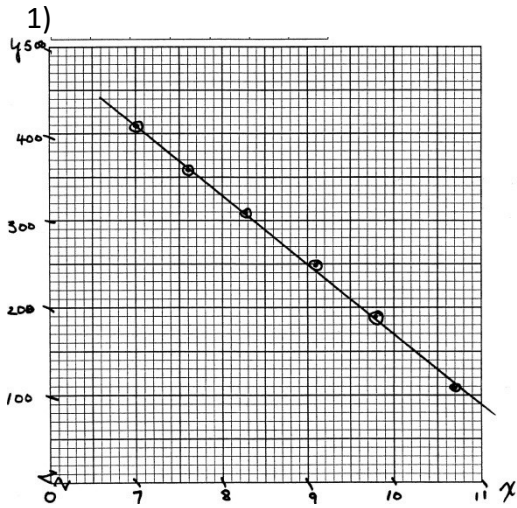

2) $m = -5, n = 14$

3) $x = 1.5, y = -4$

4) $x = 3.8, y = -0.65$

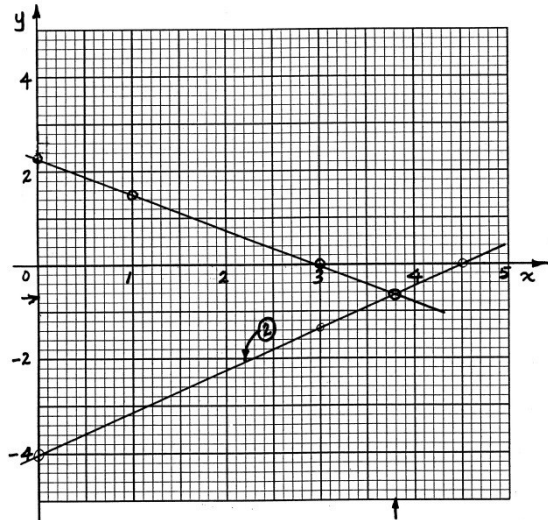

3)

a. 13.93

b. $-\frac{5}{13}$

4) a. $y = -\frac{5}{2}x + 2$; b. (5, 0); (0, 2)

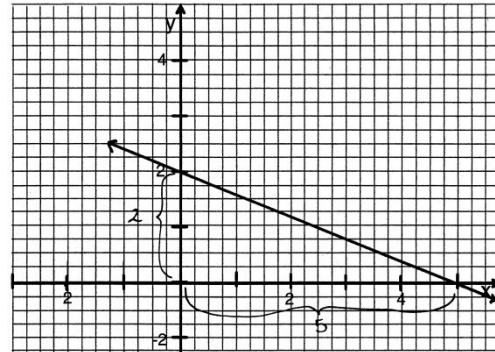

7) $y = -\frac{1}{3}x$ or $x + 3y = 0$

8) $y = \frac{5}{3}x + \frac{20}{3}$ or $5x - 3y + 20 = 0$

9) $y = x - 12.5$

Topic 14: Logarithms

- 1) Convert each given exponential equation to its equivalent logarithmic form, and convert each given logarithmic equation to its equivalent exponential form.

EXPONENTIAL FORM	LOGARITHMIC FORM
$X^3 = 346$	$\log_x 346 = 3$
$N^{3.7} = R$	$\log_N R = 3.7$
$2^P = 94$	$\log_2 94 = P$
$10^{2.43} = 3R$	$\log_{10} (3R) = 2.43$
$e^{1.5t} = 10.3$	$\ln 10.3 = 1.5t$
$e^{2x} = 5$	$\ln 5 = 2x$
$X^R = 1200$	$\log_x (1200) = R$
$x^{-2.43} = 0.7J$	$\log_x (0.7J) = -2.43$
$4^2 = 16$	$\log_4 16 = 2$

- 2) Convert to exponential form and solve for the unknown.

LOG FORM	EXPONENTIAL FORM	ANSWER
$\log_3 81 = X$	$3^X = 81$	$X = 4$
$\log_x 6 = \frac{1}{2}$	$X^{\frac{1}{2}} = 6$	$X = 36$
$\log_2 X = 4$	$2^4 = X$	$X = 16$
$\log_{10} 0.001 = X$	$10^X = 0.001$	$X = -3$
$3 = \log_R 1000$	$R^3 = 1000$	$R = 10$

- 3) Using the PROPERTIES OF LOGS expand the given log terms and combine the given log expressions:

COMBINED FORM	EXPANDED FORM
$\log_{10} \left[\frac{\pi R^2}{T} \right]$	$2\log_{10} R + \log_{10} \pi - \log_{10} T$
$\log_{10} \left[\frac{x-R}{j} \right]$	$\log_{10} (x-R) - \log_{10} j$
$\log_{10} \left[\frac{4}{x+y} \right]^{\frac{1}{2}}$	$\frac{1}{2} [\log_{10} 4 - \log_{10} (x+y)]$
$\log_{10} [2P]^{3.2}$	$3.2 [\log_{10} 2 + \log_{10} P]$
$\log_{10} [7.6 \cdot \frac{1}{2} J K]$	$\frac{1}{2} \log_{10} (7.6) + \log_{10} J + \log_{10} K$
$\log_{10} \left[\frac{5.73N}{R} \right]$	$2 [\log_{10} N + \log_{10} 5.73 - \log_{10} R]$